

4

3

2

1

B

B

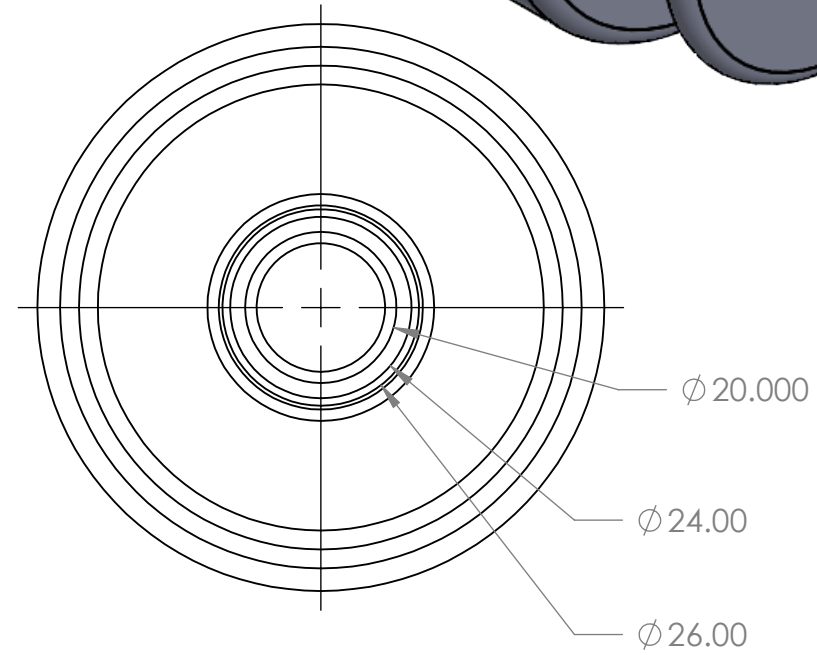
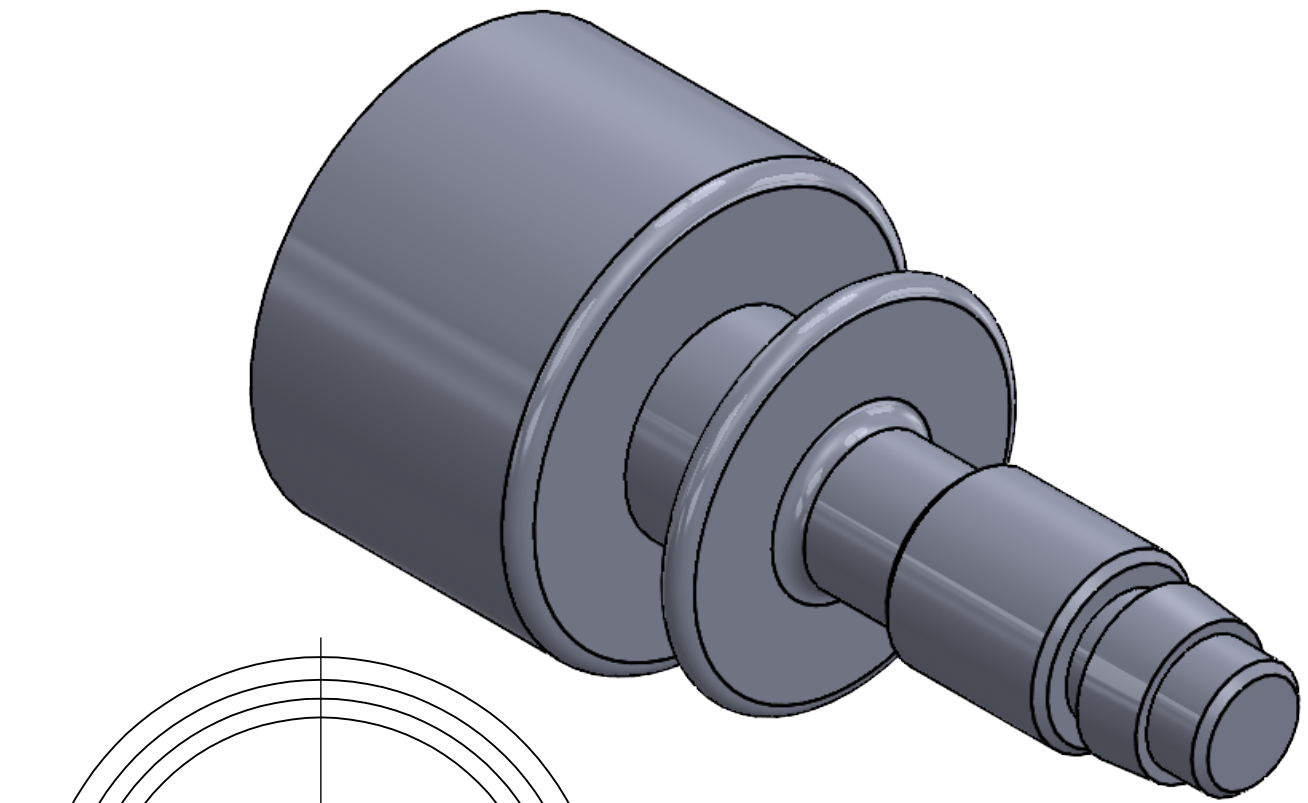
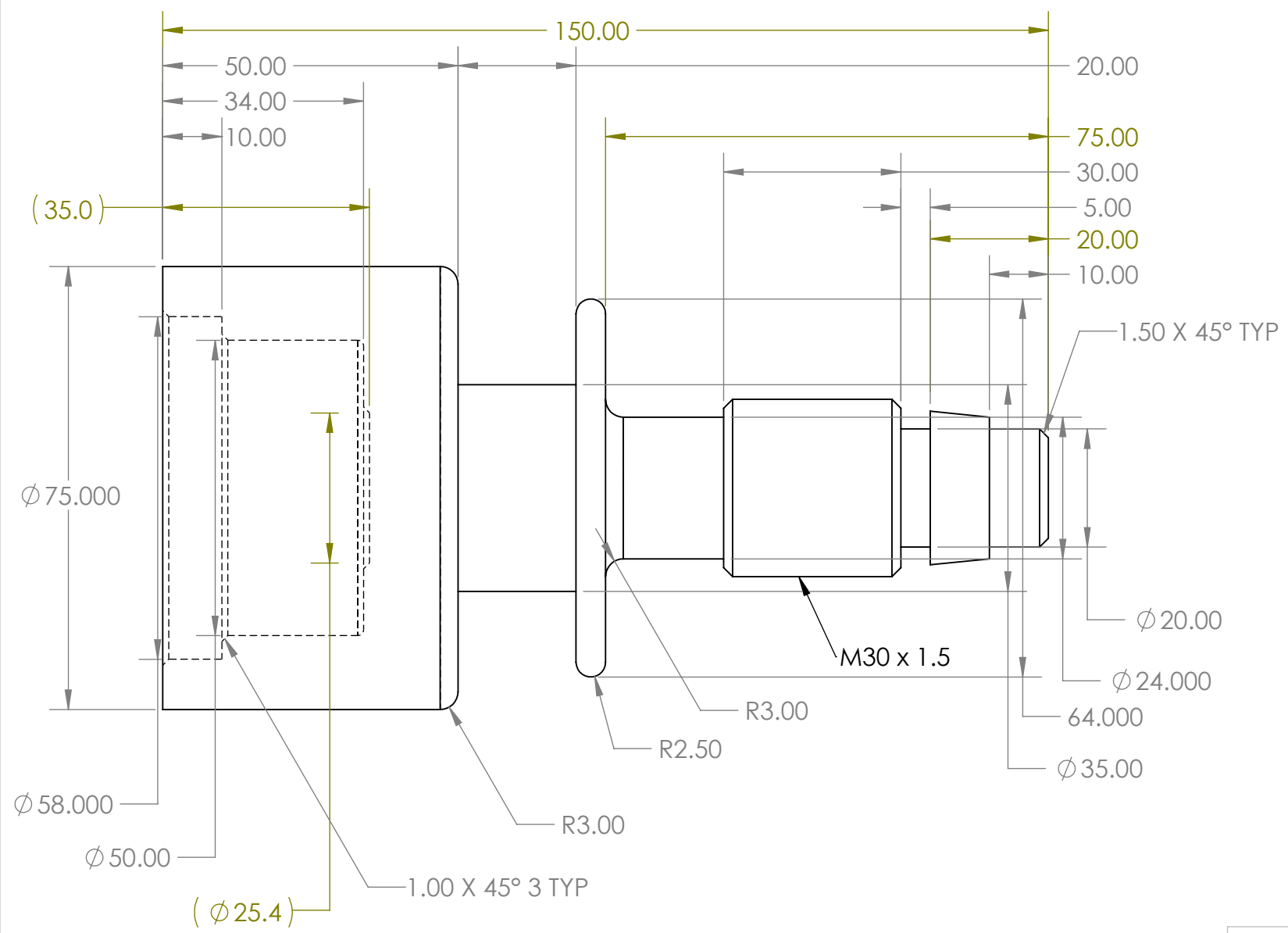

A

A

M30 x 1.5 6g	MAX	MIN
Major Diameter	29.968	29.732
Pitch Diameter	28.994	28.844

**PROPRIETARY AND CONFIDENTIAL**  
 THE INFORMATION CONTAINED IN THIS DRAWING IS THE SOLE PROPERTY OF <INSERT COMPANY NAME HERE>. ANY REPRODUCTION IN PART OR AS A WHOLE WITHOUT THE WRITTEN PERMISSION OF <INSERT COMPANY NAME HERE> IS PROHIBITED.

UNLESS OTHERWISE SPECIFIED:		NAME	DATE
DIMENSIONS ARE IN MM		DRAWN	JS 2/12/24
ANGULAR: MACH ± BEND ±		CHECKED	
ONE PLACE DECIMAL ±.1		ENG APPR.	
TWO PLACE DECIMAL ±.05		MFG APPR.	
THREE PLACE DECIMAL ±.025		Q.A.	
INTERPRET GEOMETRIC TOLERANCING PER:		COMMENTS:	
MATERIAL		CRS	
FINISH		N7	
NEXT ASSY	USED ON	DO NOT SCALE DRAWING	



SIZE	DWG. NO.	REV
<b>B</b>	Lathe 2024	
SCALE: 1:1	WEIGHT:	SHEET 1 OF 1

4

3

2

1